

PATLITE

New Frontiers in Safety, Security and Comfort.

Explosion Protection & Harsh Environment

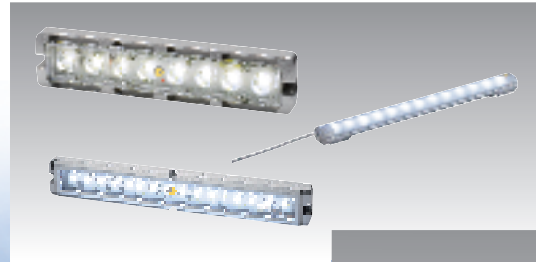

Explosion-Proof
Explosion-Safe
Intrinsically-Safe
Robust Heavy Duty



“New Frontiers in Safety, Security and Comfort” is PATLITE`s mission.

PATLITE offers state-of-the-art equipment for process and industrial automation for over 60 years. Our Innovative and robust design, backed by a powerful commitment and years of knowledge, has made PATLITE the world`s best known manufacturer of the visual and audible signaling products. We are also dedicated to the development of explosive and harsh-environment products to demonstrate our strong commitment to serving the industry with unique and innovative solutions.

In order to identify the diversified needs of our customers, and respond quickly and satisfactorily to those needs, we have implemented the POP (Point of Production) System together with a lean-manufacturing cell-based assembly system (combination, single, and flexible assembly).

These new systems allow us to handle any order rapidly from single items to customized item orders.

We`ve also reduced development time and production cost by having our own in-house machinery to produce, design and manufacture metal moldings and plastic materials with the use of injection machinery.

From designing to production, from raw material to the finished product, we also manage our quality control throughout the entire process. This is how we maintain our world class quality reputation in the visual, audible signaling and networking information products.

■ From designing to production, quality control is managed throughout the process.



● Design with 3-D CAD

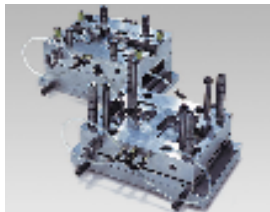

● Manufacturing of metal molding parts



● Electrical discharge machine



● Machining Center



● Injection molding machines

World-wide Sales, Marketing and After-sales Support Network.



Wide-range of Innovative and World-class Quality Products.



■ How Explosion Occurs

Mixture of oxygen and explosive substance develop explosive gases. When the concentration of the substance in air is within the lower and upper explosive limits, the mixture can be ignited.

To prevent an explosion, one of three prerequisites must be eliminated. To make equipment an ignition-free to install in explosive environment is one of the solutions.

PATLITE offers Explosion Proof, Explosion-Safe, Intrinsically-Safe visual and audible signaling products as well as LED illumination work lights in order to increase safety in the work environment.

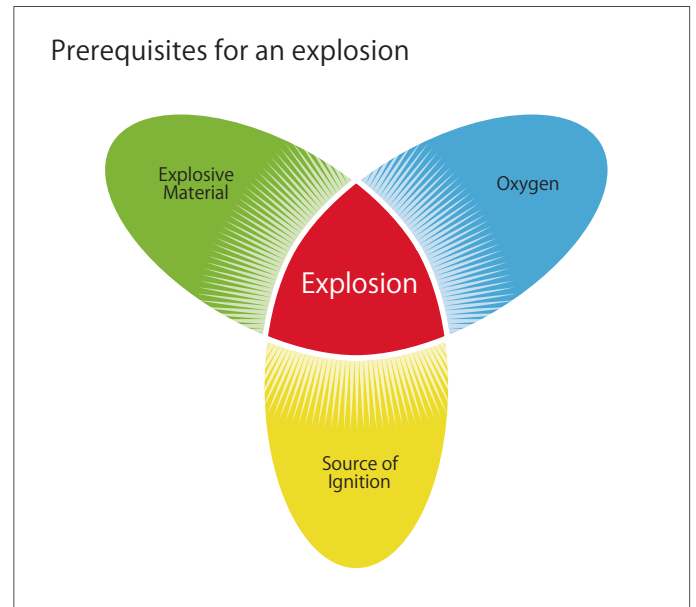

■ An explosive environment is categorized in three segments, Zone 0, Zone 1 and Zone 2, depending on the hazardous level of gases and vapors.

Zone 0

An area where an explosive atmosphere consisting of a mixture of air containing flammable substances in the form of gas, liquid, or vapor is continuously present and/or frequent.

Zone 1

An area where an explosive atmosphere consisting of a mixture of air containing flammable substances in the form of gas, liquid or vapor is likely to occur under normal











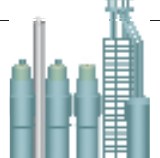

conditions on occasion.

Zone 2

An area where an explosive atmosphere consisting of a mixture of air containing flammable substances in the form of gas, liquid, or vapor is not likely to occur under normal conditions. However, if it occurs, it will only be for short periods of time.

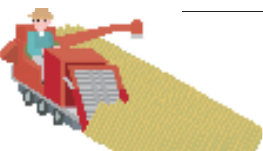

■ Various Applications for Explosion-Proof, Explosion-Safe and Harsh Environments.

	Branch	Explosion Hazard
	Power Generation Companies	<ul style="list-style-type: none"> ● Lump Coal Dust
	Woodworking Industry	<ul style="list-style-type: none"> ● Saw Dust ● Fine Wood Chips
	Metal-work Operations	<ul style="list-style-type: none"> ● Explosive Metal Dust ● Spark-ignitable Metal Dust
	Food/Beverage Industry	<ul style="list-style-type: none"> ● Ignitable Grain Dust ● Explosive Sugar Dust
	Refinery Industry	<ul style="list-style-type: none"> ● Hydrocarbons close to their flash-points ● Oil Processing Plants
	Waste Disposal Companies	<ul style="list-style-type: none"> ● Waste-water Treatment Gasses
	Landfills/Civil Engineering	<ul style="list-style-type: none"> ● Flammable Landfill Gases ● Uncontrolled Gas Emissions ● Flammable Gas from poor ventilation sources
	Pharmaceutical Industry	<ul style="list-style-type: none"> ● Alcohol Solvents ● Materials explosive when mixed
	Gas Suppliers	<ul style="list-style-type: none"> ● Natural Gas Leakage ● Natural Gas Emissions
	Paint-spraying Operations	<ul style="list-style-type: none"> ● Overspray in Spray-paint Bays ● Solvent Vapor Emissions
	Recycling Operations	<ul style="list-style-type: none"> ● Unemptied flammable gas/liquid containers ● Biodegradable Material Emitting Explosive Gasses
	Chemical Industry	<ul style="list-style-type: none"> ● Flammable Gases ● Flammable Liquids ● Flammable Solids
	Agriculture	<ul style="list-style-type: none"> ● Bio-gas Production Plants ● Bio-gas Located on Farms

Classification of Hazardous Areas

Gases/Vapors

A tank filled with flammable liquid: There is a potential risk of an explosion which may occur inside the tank. Therefore, the inside of the tank is categorized as Zone 0. Vapor may escape on occasion through the vent on the top of the tank, therefore the area around the vent is categorized as Zone 1.

The vapor may also run down the outside of the tank, developing another explosive environment, so the area around the tank is categorized as Zone 2.

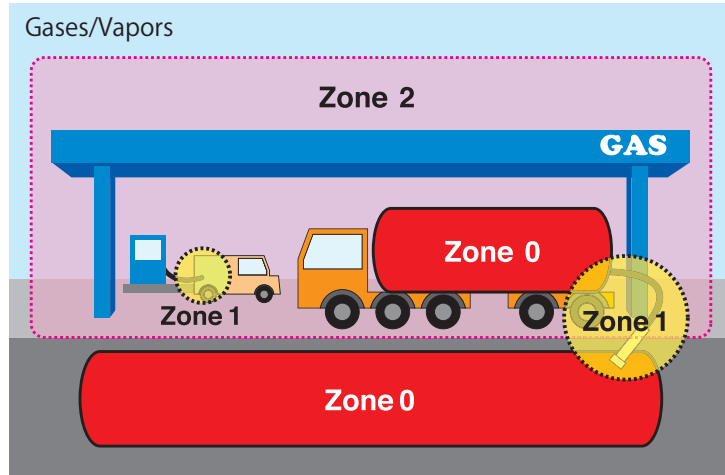

		Constant Exposure	Occasional Exposure	Rare and Temporary
ATEX	EC60079-10	Zone 0 (Category 1)	Zone 1 (Category 2)	Zone 2 (Category 3)
IEC	IEC60079-10	Zone 0	Zone 1	Zone 2
US	NEC505	Zone 0 (class I)	Zone 1 (class I)	Zone 2 (class I)
	NEC500	Division 1 (Class I)		Division 2 (Class I)

Dust

At a mill with a feed hopper and filter: A product, which causes dust particles mixed with sufficient air to cause an inflammable mixture, is loaded into a hopper. Inside the feed hopper and filter, it is categorized as Zone 20. While the product is being loaded, the mixture of dust and air

causes a potentially explosive compound in the area where the product is loaded into the hopper, so the area outside the hopper is categorized as Zone 21. Around the hopper where a potential inflammable atmosphere exists temporarily is categorized as Zone 22.

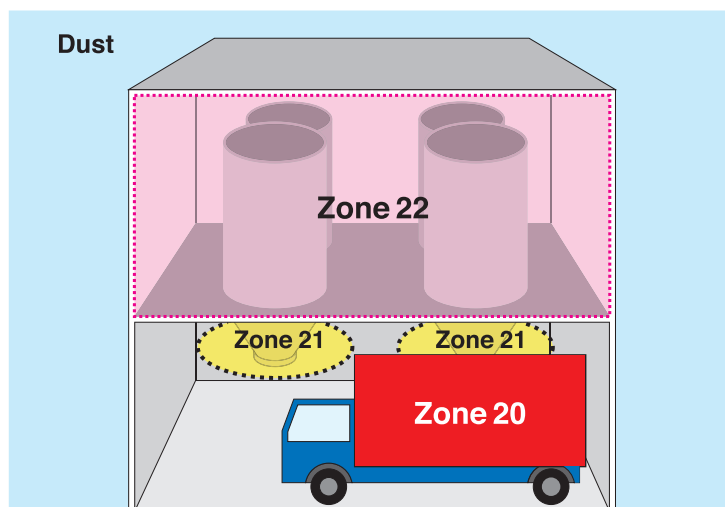

		Constant Exposure	Occasional Exposure	Rare and Temporary
ATEX	EC61241-10	Zone 20 (Category 1)	Zone 21 (Category 2)	Zone 22 (Category 3)
IEC	IEC61241-10	Zone 20	Zone 21	Zone 22
US	NEC505	—	—	—
	NEC500	Division 1 (Class II)		Division 2 (Class II)

■ Relationship of IEC, CENELEC, NEC 505 and NEC 500

IEC: International Electrotechnical Commission

CENELEC: European Committee for Electrotechnical Standardization

NEC: National Electrical Code

IEC/CENELEC	Zone 0	Zone 1		Zone 2		
USA:NEC 505	Zone 0	Zone 1		Zone 2		
USA:NEC 500	Division 1			Division 2		
	Explosive Material	Class	Group	Explosive Material	Class	Group
	Gas, Vapor or Liquid	I	A, B, C, D	Gas, Vapor or Liquid	I	A, B, C, D
	Dust	II	E, F, G	Dust	II	E, F, G
	Fibers	III	—	Fibers	III	—

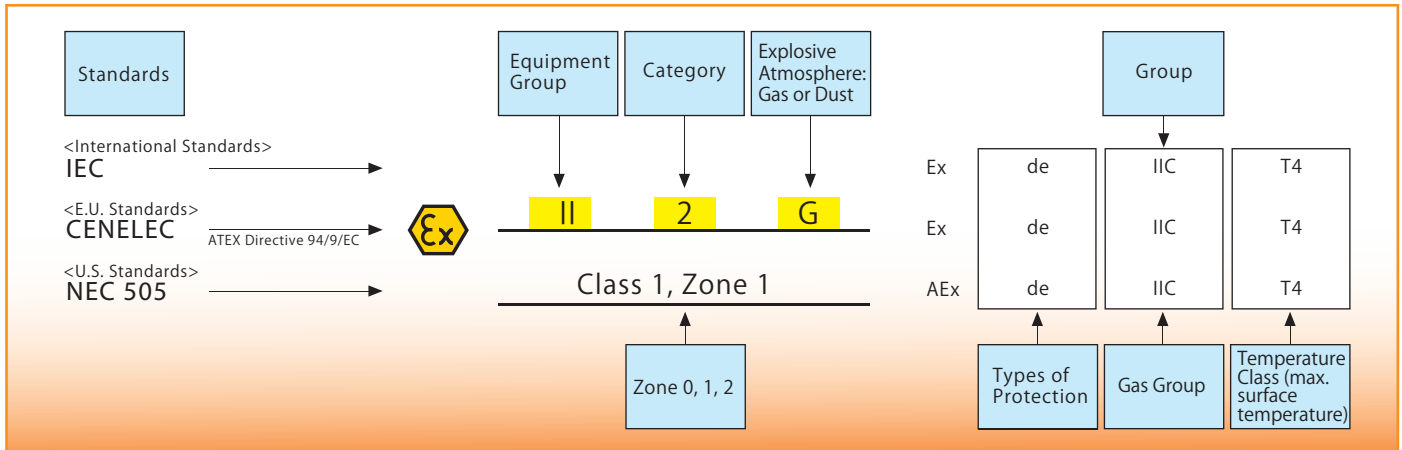

■ IP Protection Rate: Index of Ingress Protection

IP IEC60529

5	The entrance of dust is not closed completely. But dust may not go into the device in such manner as the optimal operation of the device and the safety are impaired.	5	No detrimental effect occurs when a jet-stream is applied to the test sample from any direction. (TEST: 12.5 liter/min. of water is sprayed with a jet nozzle, having an internal diameter of 6.3mm, and a distance from the test sample of 2.5m - 3m away)
		6	No detrimental effect occurs when water is sprayed onto the test sample by a jet-stream from any direction. (TEST: 100 liter/min. of water is sprayed with a jet nozzle, having an internal diameter of 12.5mm, with a distance of 2.5m - 4m away from the test sample)
		7	Water must not enter into the device. No detrimental effect occurs when the device is submerged in a depth of 1 meter of water for 30 minutes.
6	No intrusion of dust into the device	8	Water must not enter into the device. No detrimental effect occurs when the device is continuously submerged. The test conditions are to be mutually agreed upon by the manufacturer and user.

IP69K

IP69K is the German DIN 40050 PART9 standard. It is defined as a protection regulation for high temperature and high-pressurized water. Water is heated up to 80 °C and sprayed at a water pressure in the range from 80 to 100 bars at 14 to 16 liters per minute at the test object. The test object is at a distance of 100 to 150 mm from the nozzle and sprayed in all directions at 0, 30, 60, and 90 degrees, then sprayed at a horizontal angle while it is being rotated, all done for a period of 30 seconds without being affected by water penetration.

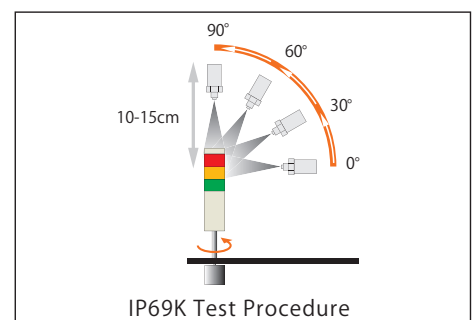

Note: Model CLA LED light bars comply with IP69K. See page 16 for more details.

Explosion-proof Maintenance Free LED Signal Lights

The EDLM and EDWM series LED signal lights are visual warning and status indicating lights for use in hazardous locations that requires compliance with the ATEX Directive 94/9/EC (CENELEC standard) or NEC Article 505 certification.

The EDLM and EDWM series offers wide range of voltages and versatile mounting options to meet various applications. The following chart explains the comparison between the ATEX Directive 94/9/EC (CENELEC standard) and NEC Article 505 certification. To find the most suitable models, refer to page 9 and 10.



EDLM

EDWM



Protection Method (ATEX/IEC)



Flame-proof Enclosure Type "d"
In flame-proof enclosures, an explosion is contained.



Protection Type "tD"
Dust-protected and flame-proof enclosure.

Standard Markings

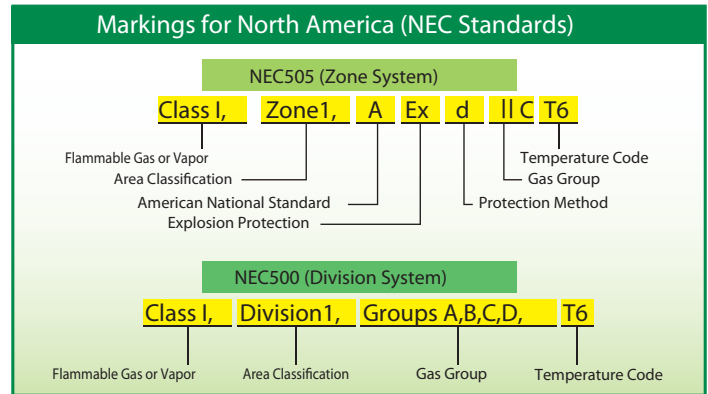
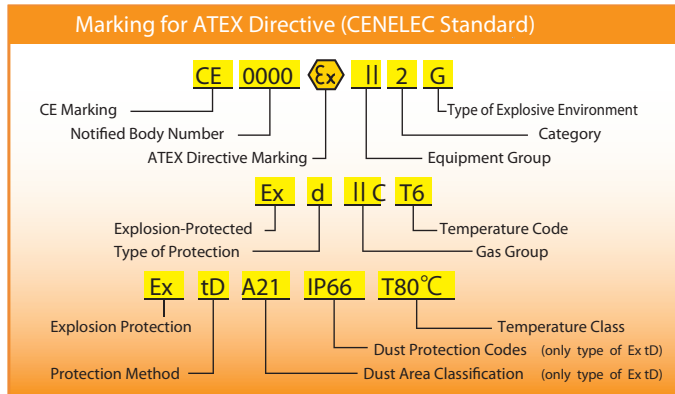

Explosion-proof Protection

Protection Method	Europe (ATEX Directive / CENELEC) International (IEC)				North America Class I				
	Protection Code	Zone	CENELEC ATEX	IEC IECEx	NEC505		NEC500		
					Protection	Zone	US	Division	US
Flameproof	Ex d	1, 2	EN60079-1	IEC60079-1	AEx d	1, 2	ANSI/ISA 60079-1	1, 2	FM3615 UL1203
Increased Safety	Ex e	1, 2	EN60079-7	IEC60079-7	AEx e	1, 2	ANSI/ISA 60079-7	—	—
Intrinsic Safety (2 faults)	Ex ia	0, 1, 2	EN60079-11	IEC60079-11	AEx ia	0, 1, 2	ANSI/ISA 60079-11	1, 2	FM3610 UL913
Intrinsic Safety (1 fault)	Ex ib	1, 2	EN60079-11	IEC60079-11	AEx ib	1, 2	ANSI/ISA 60079-11	—	—
Purged/Pressurized	Ex p	1, 2	EN60079-2	IEC60079-2	AEx p	1, 2	ANSI/ISA 60079-2	1, 2	FM3620 NFPA496
Encapsulation	Ex m	1, 2	EN60079-18	IEC60079-18	AEx e	1, 2	ANSI/ISA 60079-18	—	—
Non-incineraries	—	—	—	—	—	—	—	2	FM3611 UL1604
Type-n	Ex n	2	EN60079-15	IEC60079-15	AEx n	2	ANSI/ISA 60079-15	—	—

Zone Classification

	CENELEC IEC	NEC505	Hazardous Area Classification
Gases	Zone 0	Class 0 Zone 0	An area where the mixture of explosive gas is continuously present or present for long periods.
	Vapors	Zone 1	Class 1 Zone 1
		Zone 2	Class 2 Zone 2
Dust	Zone 20	—	An area where the mixture of incendiary dust is continuously present or present for long periods.
	Zone 21	—	An area where the mixture of incendiary dust can be present during normal operation.
	Zone 22	—	An area where the mixture of incendiary dust is not normally present, but if it occurs, it will only be for brief periods of time.

ATEX Directive (CENELEC)

Equipment Group	Category- Protection Level	Explosive Environment	Flammable Substances	Hazardous Areas
-mines	M1- Very High Level	Constant Exposure	Methane	—
	M2- High Level	Occasional Exposure	Coal Dust	—
-other areas	1- Very High Level	Constant Exposure	Gases	Zone 0 (Gases) Zone 20 (Dust)
	2- High Level	Occasional Exposure	Vapors	Zone 1 (Gases) Zone 21 (Dust)
	3- Normal Level	Rare and Temporary	Mists	Zone 2 (Gases) Zone 22 (Dust)

ATEX/IEC Classification for Gases & Temperature Coding

	T1 (450)	T2 (300)	T3 (200)	T4 (135)	T5 (100)	T6 (85)
☒ Methane	—	—	—	—	—	—
☒ A Acetone ethane propane	Ethyl Alcohol Cyclohexane n-butane	Gasoline Aircraft fuel Diesel fuel	Acetaldehyde	—	—	—
☒ B Lighting gas Acrylonitrile	Ethylene Ethylene oxide	Ethylene glyco Hydrogen sulphide	Ethyl-ether	—	—	
☒ C Hydrogen	Acetylene	—	—	Carbon Bisulfide	Coal disulphide	

Explosion-Safe Visual/Audible Signaling Products & LED Light Bars

A wide range of visual and audible signaling products, as well as super bright LED light bars, designed for use in hazardous locations that require the ATEX Directive 94/9/EC (CENELEC Standard). These unique and innovative models meet the criteria for Zone 2 (gas)

and Zone 22 (dust) atmospheres. The CLA series LED light bars meets the criteria for intrinsically safe applications.



LED Signal Towers				Hazardous Area	
Model Selection	Page	CENELEC Standard	Explosion Safety		
AR-070 Series	11	EN60079-0, EN60079-15	CE I DG Ex nA II T4, Ex tD A22 IP65 T85		Zone2 Zone22
AR-078 Series	12	EN60079-0, EN60079-15	CE DG Ex nA II T4, Ex tD A22 IP65 T85		Zone2 Zone22
MP3 Field Programmable Annunciator integrated with LED tower				Hazardous Area	
Model Selection	Page	CENELEC Standard	Explosion Safety		
LKEHFV/EXN	13	EN60079-0, EN60079-15	CE I DG Ex nA II T4, Ex tD A22 IP65 T85		Zone2 Zone22
LKEHFE/EXN	13	EN60079-0, EN60079-15	CE DG Ex nA II T4, Ex tD A22 IP65 T85		Zone2 Zone22
Voice Annunciator, Melodies & Chimes Horns				Hazardous Area	
Model Selection	Page	CENELEC Standard	Explosion Safety		
PVW04JF/EXN	14	EN60079-0, EN60079-15	CE I DG Ex nA II T4, Ex tD A22 IP65 T85		Zone2 Zone22
EWH24E/EXN	15	EN60079-0, EN60079-15	CE DG Ex nA II T4, Ex tD A22 IP65 T85		Zone2 Zone22
Super Bright LED Light Bars				Hazardous Area	
Model Selection	Page	CENELEC Standard	Explosion Safety		
CLT3024S-CD	16	EN60079-0, EN60079-15	CE I DG Ex nA II T4, Ex tD A22 T135		Zone2 Zone22
CLF2024/EXN	16	EN60079-0, EN60079-15	CE DG Ex nA II T4, Ex tD A22 T135		Zone2 Zone22
CLA series	16	EN60079-15	CE DG Ex nL IIC T4, Ex iD A22 T135		Zone2 Zone22

* These products are manufactured by PATLITE, converted to Ex Certification by Artidor, and sold by Patlite.

Markings

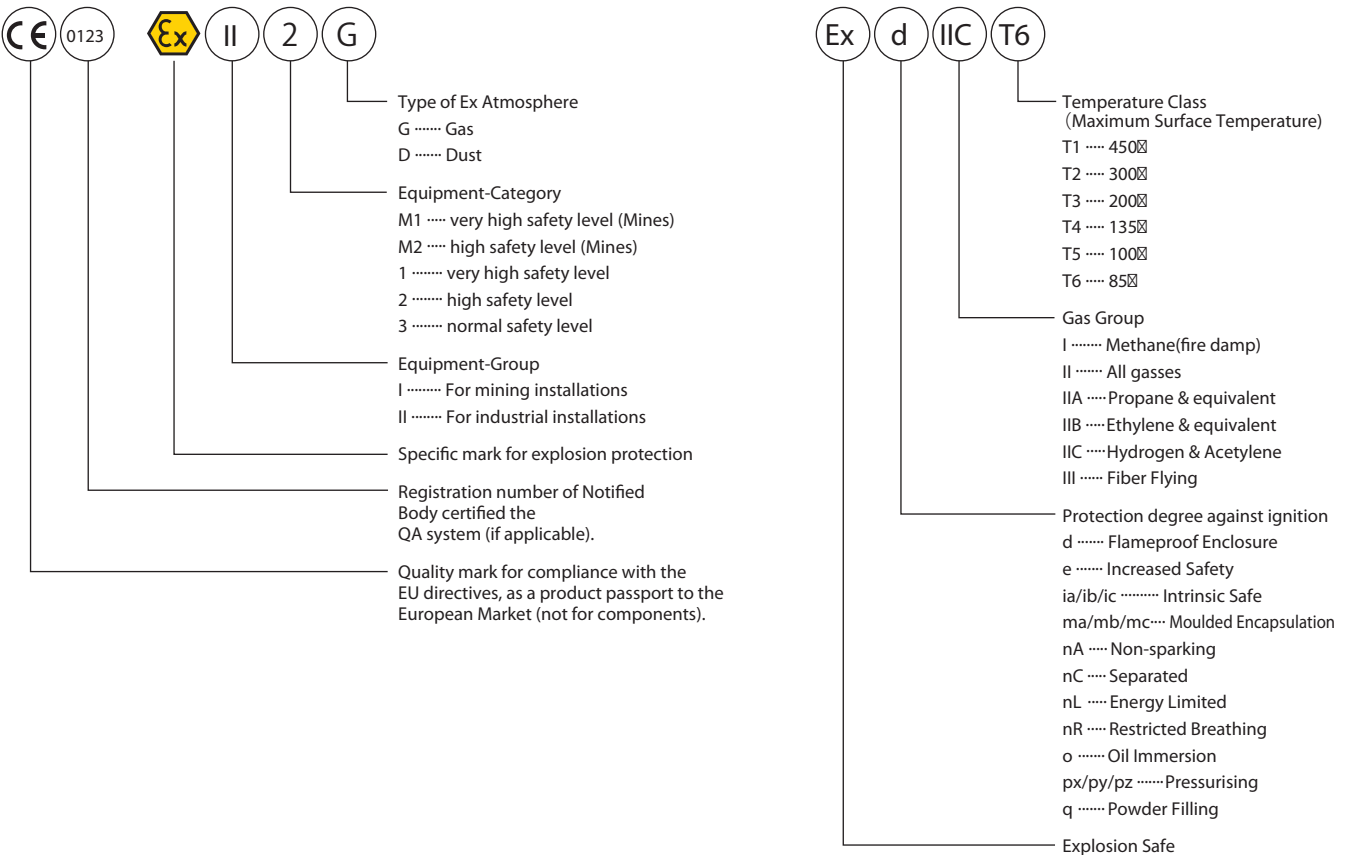

EDLM SERIES & EDWM SERIES EXPLOSION-PROOF



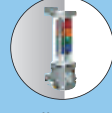

Wall Mount



Horizontal Mount



Vertical Mount

■ Descriptions

The EDLM (colored 3 tiered LED) and EDWM (colored 5 tiered LED) are innovative LED maintenance free Signal Towers. The robust design with pressure and flame-proof housing is ideal for use in potentially flammable and hazardous explosive atmospheres such as chemical, petrochemical, combustible dust, production of mineral/natural gas, and even in the manufacturing of polysilicon for the photovoltaic, semi-conductor industries, as well as the food and beverage industries.

■ Features

- Housing: Aluminum alloy
- Glass: Borosilicate glass
- Terminals: Easy wire connection to the Signal Tower by opening the bottom
- Mounting: Upright, Wall Mount, Vertical-mount, and Horizontal Mount
- LED color: Different color configurations are possible to custom-design
- Voltage: 24VAC/DC, 120VAC, 230VAC, 90-250VAC are available.
- Wire core size: 0.5mm²~0.8mm², AWG20~AWG18

■ EDLM & EDWM meet the specifications shown in the shaded areas below

CENELEC Standards for Europe

• ATEX directive is CENELEC standard.

Classification	Standard	PATLITE Models	Present Continuously	Present Intermittently	Present Abnormally
ATEX, IEC/EU Directive 94/9/EC	IEC 60079-10 EN 60079-10	EDLM, EDWM	Zone 0	Zone 1	Zone 2

NEC Standards for the USA

• NEC standard is National Electrical Code.

Classification	Standard	PATLITE Models	Present Continuously	Present Intermittently	Present Abnormally
NEC Article 505	ANSI/NFPA 71	EDLM, EDWM	Zone 0	Zone 1	Zone 2
NEC Article 500	ANSI/NFPA 70	—	Division 1		Division 2

■ CENELEC (ATEX Directive)

Model	EDLM-302FE	EDLM-312FE	EDLM-323FE	EDWM-502FE	EDWM-5M2FE
Voltage Rating	AC/DC 24V	AC 120V	AC 230V	AC/DC 24V	AC 90~250V
Signal line Current (Per LED Module)	Red/Amber: 52.5mA Green: 20.0mA			Red: 22.6mA, Amber: 26.6mA, Green: 17.5mA Blue/White: 38.9mA	
Explosion Protection Ratings	Ⓔ Ⓔ2G Ex d Ⓔ T6 (Zone1,2) Ⓔ Ⓔ2D Ex tD A21 IP66 T80Ⓔ (Zone21,22)				
Operating Temperature	-20Ⓔ~+50Ⓔ (no ice)				
Operating Humidity	45%~85%RH (Keep from dew condensation)				
Ambient Pressure	80~110kpa				
Lighting Pattern	Flashing (60±12 flashes per minute) / Continuous Light				
Protection Rating	IP66				
Vibration Resistance	9.8m/s ²				
Mounting	Outdoor & Indoor Upright			Outdoor & Indoor Upright & Sideways	
Luminosity	Red: 350mcd, Amber: 580mcd Green: 1300mcd			Red/Green/White: 1000mcd Amber: 700mcd, Blue: 300mcd	
Mass (Main Body)	4.3kg			4.7kg	
Material	Upper & Lower Case : Aluminum Alloy (Housing Finish: Melamine-baked Finish) Glass Case : Borosilicate Glass Fitting Bracket : Stainless Steel (SUS 316) Cable Gland : Brass				

■ NEC Article 505

Model	EDLM-302FA	EDLM-312FA	EDLM-323FA	EDWM-502FA	EDWM-5M2FA
Voltage Rating	AC/DC 24V	AC 120V	AC 230V	AC/DC 24V	AC 90~250V
Signal line Current (Per LED Module)	Red/Amber: 52.5mA Green: 20.0mA			Red: 22.6mA, Amber: 26.6mA, Green: 17.5mA Blue/White: 38.9mA	
Explosion Protection Ratings	Class Ⓔ, Zone 1 AEx d Ⓔ T6				
Operating Temperature	-25Ⓔ~+50Ⓔ (No Frezing)				
Operating Humidity	45%~85%RH (Keep from dew or condensation)				
Ambient Pressure	80~110kpa				
Lighting Pattern	Flashing (60±12 flashes per minute) / Continuous Lighting				
Protection Rating	IP66				
Vibration Resistance	9.8m/s ²				
Mounting	Outdoor & Indoor Upright			Outdoor & Indoor Upright & Sideways	
Luminosity	Red: 350mcd, Amber: 580mcd Green: 1300mcd			Red/Green/White: 1000mcd Amber: 700mcd, Blue: 300mcd	
Mass (Main Body)	4.3kg			4.7kg	
Material	Upper & Lower case : Aluminum Alloy (Housing Finish: Melamine-baked Finish) Glass case : Borosilicate Glass Fitting Bracket : Stainless,Steel (sus 316)				

Dimensions (EDLM, EDWM)

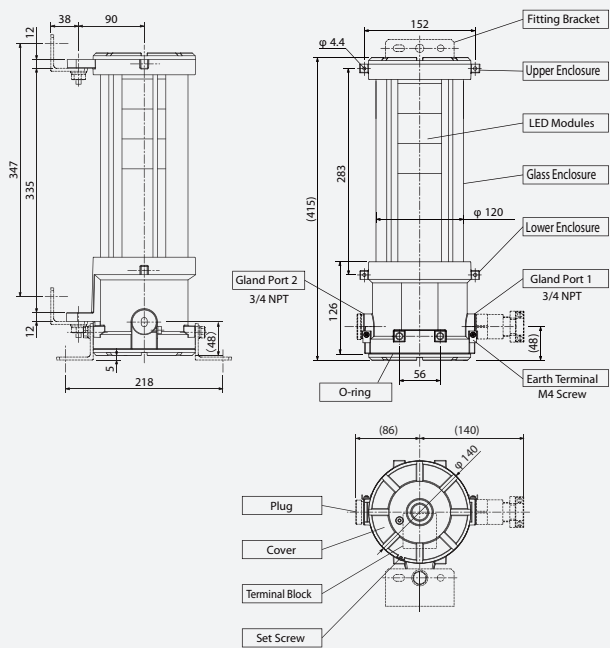

■ installation (Wall-mount)

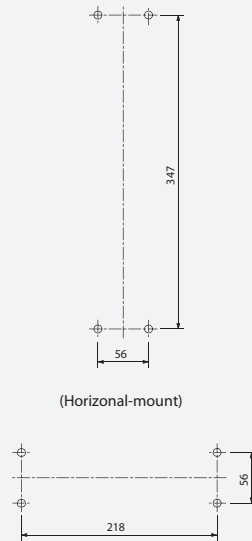

■ Cable Gland*

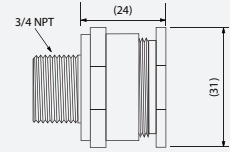

*ATEX Model ... Standardized Part
*NEC Model Non-Standardized Part

■ Flush-mount Bracket

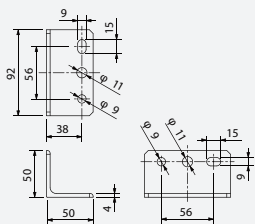

(Unit: mm)

Wiring Diagram
EDLM (3 color LED)

■ EDLM-302FE/FA

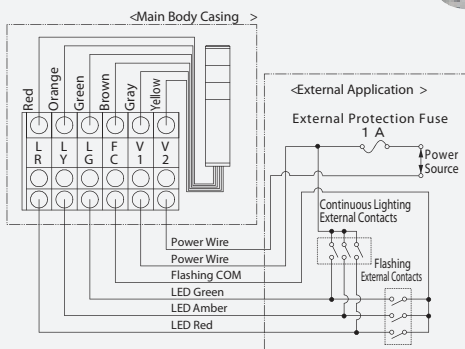

■ EDLM-312FE/FA
EDLM-323FE/FA

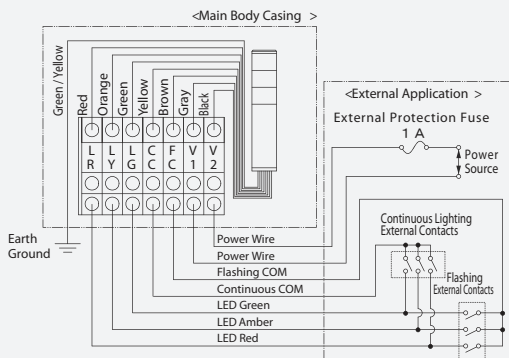

Wiring Diagram
EDWM (5 color LED)

■ EDWM-502FE/FA

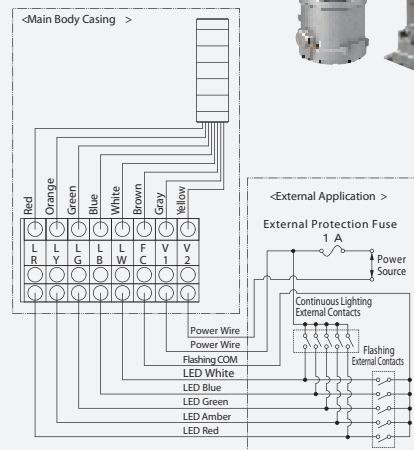

■ EDWM-5M2FE/FA

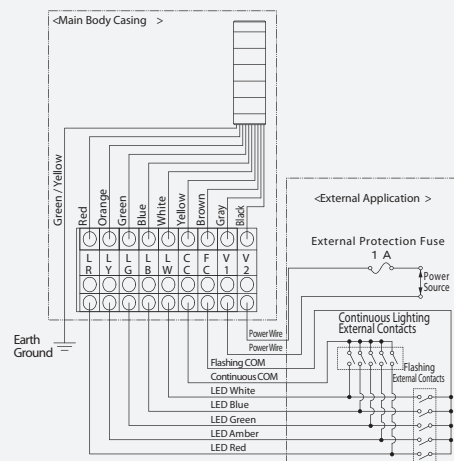

AR-070 SERIES EXPLOSION-SAFE

CE II 3 GD; Ex nA II T4; Ex tD A22 IP65 T85° C 94/9/EC (ATEX) and 2004/108/EC (EMC) EN60079-0, EN60079-15, EN61241-0, EN61241-1

Explosion-safe Signal Light Ø40mm



Description

Explosion-safe Signal Light featuring an LED light that is versatile and energy-efficient. The vertical and horizontal cut lenses in combination with a double-reflection system enhances the LED light diffusion to create a unique, full and brilliant light. The lenses and main body are made of strong synthetic materials with characteristics to withstand harsh environments. The Signal Light can be ordered in any combination from 1 to 5 LED units with any color combination. In addition to its "continuous lighting" condition, the Signal Light can also be ordered with flashing / non-flashing functions, as well as with two super-loud alarm sounds with an 85dB (at 1m) output.

Features

- Explosion-safe for gas and dust
- Suitable for Zone 2 and Zone 22
- CE compliance in accordance to ATEX
- Full and brilliant lumination
- LED double reflection lighting system
- Different lens colors available
- From 1 to 5 tiers
- Available with "flashing/non flashing" and two audible buzzer alarm sounds
- Ingress protection of IP65
- Wall mount or direct mount



AR-070 series



Dimensions

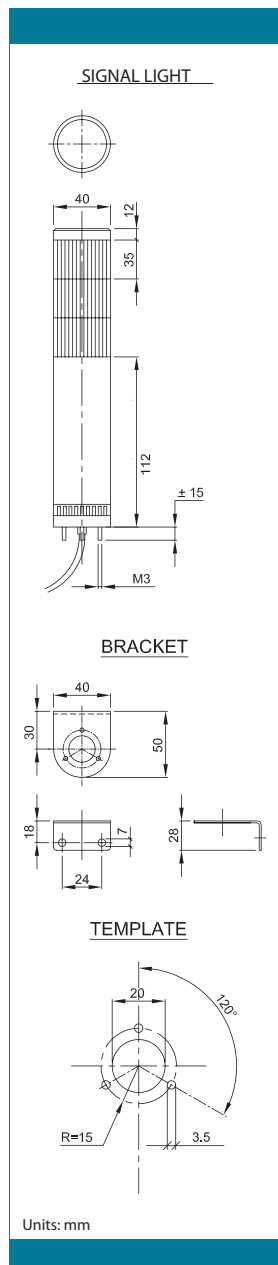

Specifications

Explosion-safety:	CE II 3 GD; Ex nA II T4; Ex tD A22 IP65 T85°C
CE conformities:	EN 60079-0, EN 60079-15, EN 61241-0, EN 61241-1
Certification:	EC-Declaration of conformity
Ambient Temperature:	-30 °C to +60 °C
Ingress Protection:	IP65 to EN 60529
Material:	ABS towerbody, polyester glassfibre reinforced base
Lighting Source:	Multiple LEDs with double reflection system
Acoustical Source:	Buzzer 85 dB (1m) with two different tones
Rated Voltage:	24 V AC/DC
Assembly position:	As desired
Activation Time:	100%
Module Colors Available:	Red, Amber, Green, Blue, Clear/white
Cable:	Factory sealed cable, Ø 8 mm, length 3 meter

LED		BUZZER	
Signal	Line Current	Signal Line Current	Inrush Current
Red, Amber	approx. 30 mA	Green, Blue, Clear	approx. 40 mA
			approx. 250 mA

CONNECTION DIAGRAMS

continuous light AC/DC 24V

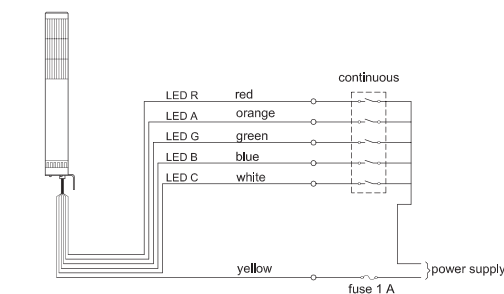

continuous and flashing light with alarm AC/DC 24V

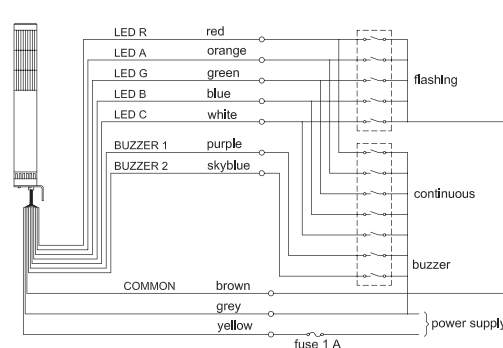

EXPLOSION-SAFE SIGNAL LIGHT							
How to order	Code	Voltage	Code	No. of Stacks	Code	Colors*	Code
Continuous lighting (only)	1	24V AC/DC	1	1-5	1	Red	R
					2	Amber	Y
Continuous/Flashing lighting and two Audible alarms	2				3	Green	G
					4	Blue	B
					5	Clear/White	C

→ Type number AR-070 0 1 / - RYGBCC *Colors are arranged from top to bottom

AR-078 SERIES EXPLOSION-SAFE

CE II 3 GD; Ex nA II T4; Ex tD A22 IP65 T85° C 94/9/EC (ATEX) and 2004/108/EC (EMC) EN60079-0, EN60079-15, EN61241-0, EN61241-1



Explosion-safe Signal Light Ø60mm

Description

Explosion-safe Signal Light featuring an LED light that is versatile and energy-efficient. The vertical and horizontal cut lenses in combination with a double-reflection system enhances the LED light diffusion to create a unique, full and brilliant light. The lenses and main body are made of strong synthetic materials with characteristics to withstand harsh environments. The Signal Light can be ordered in any combination from 1 to 5 LED units with any color combination. In addition to its "continuous lighting" condition, the Signal Light can also be ordered with flashing / non-flashing functions, as well as with two super-loud alarm sounds with an 90dB (at 1m) output.

Features

- Explosion-safe for gas and dust
- Suitable for Zone 2 and Zone 22
- CE compliance in accordance to ATEX
- Full and brilliant lumination
- LED double reflection lighting system
- Different lens colors available
- From 1 to 5 tiers
- 3/4" NPT bracket for pole mount is available as an option.
- Available with "flashing/non flashing" and two audible buzzer alarm sounds
- Ingress protection of IP65
- Wall mount or direct mount



AR-078 series



Dimensions

SIGNAL LIGHT
60, 41, 12, 124, 14, M4

BRACKET
60, 40, 70, 23, 31, 42

TEMPLATE
20, 15, 4.5, R=20, 120°

3/4" NPT bracket (Option)
60, 4.5, 120°

Units: mm

Specifications

Explosion-safety:	II 3 GD; Ex nA II T4; Ex tD A22 IP65 T85°C
CE conformities:	EN 60079-0, EN 60079-15, EN 61241-0, EN 61241-1
Certification:	EC-Declaration of conformity
Ambient Temperature:	-30 °C to +60 °C
Ingress Protection:	IP65 to EN 60529
Material:	ABS towerbody, polyester glassfibre reinforced base
Lighting Source:	Multiple LEDs with double reflection system
Acoustical Source:	Buzzer 90 dB (1m) with two different tones
Rated Voltage:	24 V AC/DC
Assembly position:	As desired
Activation Time:	100%
Module Colors Available:	Red, Amber, Green, Blue, Clear/white
Cable:	Factory sealed cable, Ø 8 mm, length 3 meter

LED		BUZZER	
Signal	Line Current	Signal Line Current	Inrush Current
Red, Amber	approx. 30 mA	approx. 40 mA	approx. 250 mA
Green, Blue, Clear	approx. 25 mA		

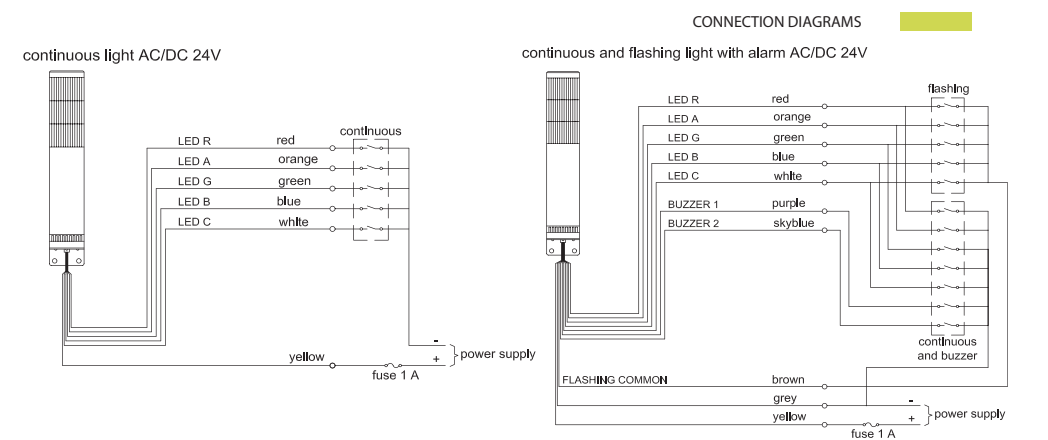

EXPLOSION-SAFE SIGNAL LIGHT							
How to order	Code	Voltage	Code	No. of Stacks	Code	Colors*	Code
Continuous lighting (only)	1	24V AC/DC	1	1-5	1	Red	R
					2	Amber	Y
Continuous/Flashing lighting and two Audible alarms	2				3	Green	G
					4	Blue	B
					5	Clear/White	C

→ Type number AR-078 0 1 / - RYGB C *Colors are arranged from top to bottom

LKEHFE/EXN, LKEHFV/EXN EXPLOSION-SAFE

CE II 3 GD; Ex nA II T4; Ex tD A22 IP65 T85° C 94/9/EC (ATEX) and 2004/108/EC (EMC) EN60079-15, EN60079-0, EN61241-1, EN61241-0



105dB(A) MP3 Field Programmable Annunciator, Melody Horn

- Explosion-safe for gas and dust
- Suitable for Zone 2 and Zone 22
- CE compliance in accordance to ATEX
- Super bright LED colors correspond to different voice, sounds, chimes and melodies.
- Voice alert messages of up to 63 seconds (64kbit/s) with 5 channels can be played back.
- 32 combinations of sounds, chimes and melodies are pre-recorded.
- 8 sounds can be played back by a bit input, and 32 sounds by binary input.
- Volume is adjustable from 0 to 105dB at 1 meter.
- Field programmable with MP3 by SD card for the model LKEHFV/EXN.
- Well visible with the super bright 100mm diameter LED from far distance.
- Robust design to withstand against 2G vibration.
- The body is made of Acrylonitrile-Ethlene-Styrene for weather resistant.
- Easy to control by only one common wire for both LED units and audible signals.
- NPN is standard. PNP open collector type is also available on order.
- Protection rating of IP65



LKEHFV/EXN, LKEHFE/EXN



Dimensions

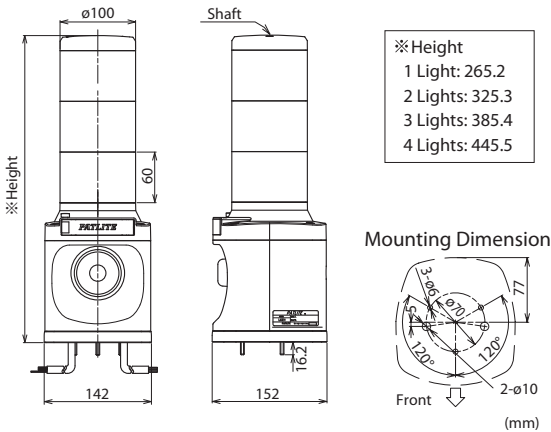

Model	MP3	LED stack	Power
LKEHFE-F/EXN	—	3	14.2W
LKEHFE-W/EXN	—	3	14.2W
LKEHFV-F/EXN	Supports	3	14.2W
LKEHFV-W/EXN	Supports	3	14.2W

- LED units can be stacked to 1, 2, and 4 on order.
- SD card for the model LKEHFV-F/EXN and LKEHFV-W/EXN sold separately.

Sound Selection Charts

- 32 sounds are pre-recorded in one unit. 4 sound types are available.
- 8 sounds can be played back by a bit input, and 32 sounds by binary input.

Beep	Stutter + Bell	Inverted Revelle	Annie Laurie
Stutter	Synthesized Melody	Galactic Motor	London Bridge
Bell	Chime	Ringin Phone	Mary's Lamb
Yelp	Call Sign	Two Tone	Camptown Races
Rapid Hi Lo	Train Ride	Alarm Clock	Amaryllis
Melody Chime	Galloping Hi Lo	Ringin Hi Lo	Symphony #40
Synthesized Piano	Alien Chatter	Fur Elise	Ave Maria
Synthesized Bell	Falling Crystals	Minuet	Grandfather's Clock

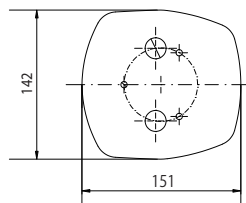

Flush mount bracket for LKEHFE-F/EXN & LKEHFV-F/EXN

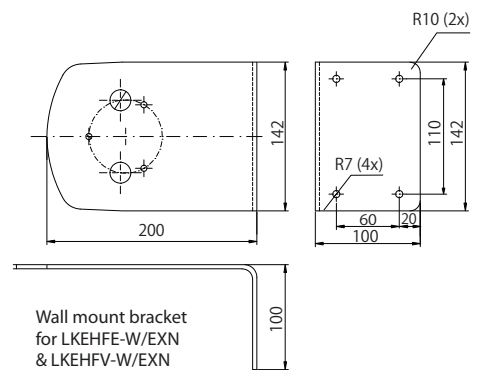

Wall mount bracket for LKEHFE-W/EXN & LKEHFV-W/EXN

Specifications

Model	Rated Voltage	Voltage Range	MP3, Melody	Operating Temperature	Recordable Duration	Sound Pressure (at 1m)	Mounting Brackets	Messages	Mass
LKEHFE-F/EXN	24VDC	24VDC +/-10%	Type-E	-10C to +50C, Humidity 85% or less	Prerecorded	105dB	Flush mount	8ch bit input, 32ch binary input	2.8Kg
LKEHFE-W/EXN			Type-E		Prerecorded		Wall mount	8ch bit input, 32ch binary input	3.2Kg
LKEHFV-F/EXN			MPEG1-Audio layer III, 64kbit/s		63 sec.		Flush mount	5ch bit input, 31ch binary input	2.8Kg
LKEHFV-W/EXN			MPEG1-Audio layer III, 64kbit/s		63 sec.		Wall mount	5ch bit input, 31ch binary input	3.2Kg

PVW04JF/EXN EXPLOSION-SAFE

CE II 3 GD; Ex nA II T4; Ex tD A22 IP65 T85° C 94/9/EC (ATEX) and 2004/108/EC (EMC) EN60079-15, EN60079-0, EN61241-1, EN61241-0

105dB (at 1m)

Voice Annunciator ADPCM 64kbit/s



- Explosion-safe for gas and dust
- Suitable for Zone 2 and Zone 22
- CE compliance in accordance to ATEX
- 4 pre-recordable messages on EPROM
- Maximum 63 seconds for recording time.
- Adjustable audible sound volume up to 105dB at 1 meter
- ADPCM 64kbit/s clear sound quality from an LSI digital voice synthesizer.
- Indoor Installation: upright, inverted, and sideways.
- Outdoor: upright installation only.
- Provided with an anti-corrosive stainless steel mounting bracket.
- 12/24VDC & 12/24VAC
- Protection rating of IP65

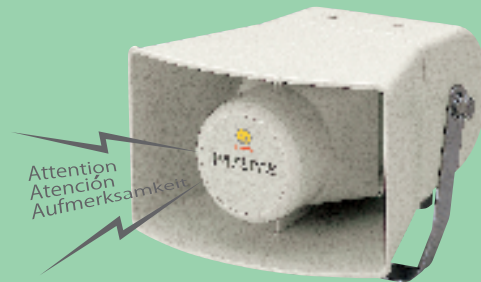

PVW04JF/EXN



■ Dimensions

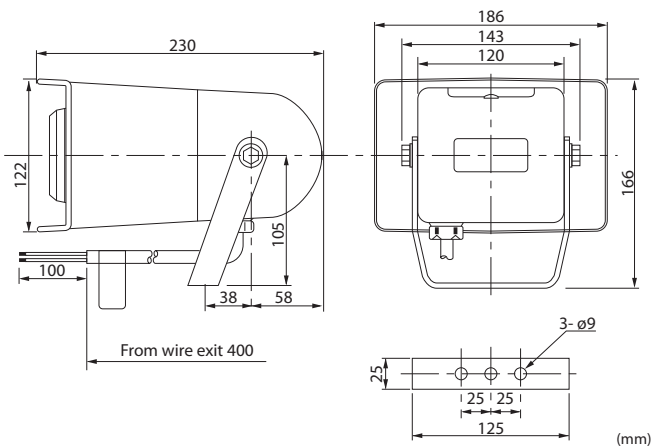

■ Wiring Diagram

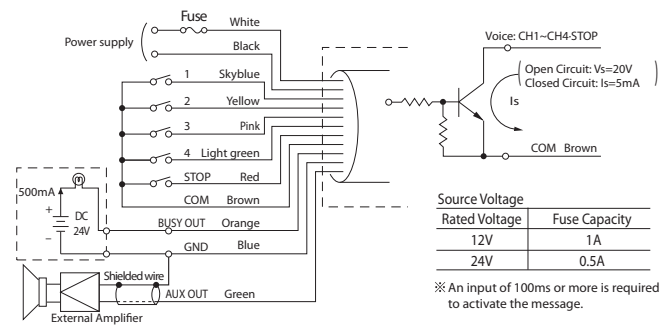

Channel Priority

STOP (Red) > CH4 (Light green) > CH3 (Pink) > CH2 (Yellow) > CH1 (Skyblue)

Note: The greater number has priority when any of the channels are activated simultaneously.

■ Specifications

Model	Rated Voltage	Voltage Range	Power Consumption	Volume	Outer Contact Capacity	Operating Temperature Range	Auxiliary Input	Channel	AUX Output	BUSY Output	Max Message Time	Protection	Mass
PVW04JF/EXN	12/24V AC/DC	8~28V AC 9~35V DC	12W	Max. 105dB at 1m	More than 10mA	-10°C~+55°C Humidity 85% or less.	Non-voltage Contact 4/1bit	4	-10dBv 600Ω	Max. load 24V DC 500mA	63 sec.	IP65	1.3kg

EWH24E/EXN EXPLOSION-SAFE

CE II 3 GD; Ex nA II T4; Ex tD A22 IP65 T85°C 94/9/EC CENELEC: EN60079-15, EN60079-0, EN61241-1, EN61241-0

105dB (at 1m) Melodies & Chimes Horn

- Explosion-safe for gas and dust
- Suitable for Zone 2 and Zone 22
- CE compliance in accordance to ATEX
- 32 combinations of melodies, chimes and sounds are pre-recorded.
- Adjustable audible sound volume up to 105dB at 1 meter
- Indoor Installation: upright, inverted, and sideways.
- Outdoor: upright installation only.
- Provided with the anti-corrosive stainless steel mounting bracket.
- NPN is standard for the EWH type. PNP open collector is available on order.
- CE compliant : 24VAC/DC only
- IP65



EWH24E/EXN



■ Dimensions

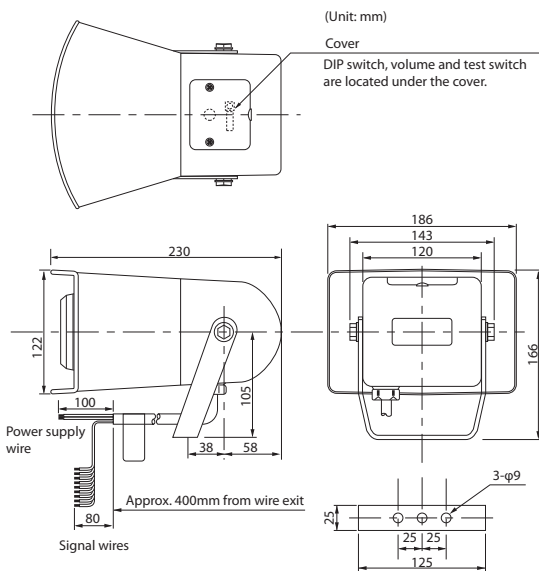

■ Wiring Diagram

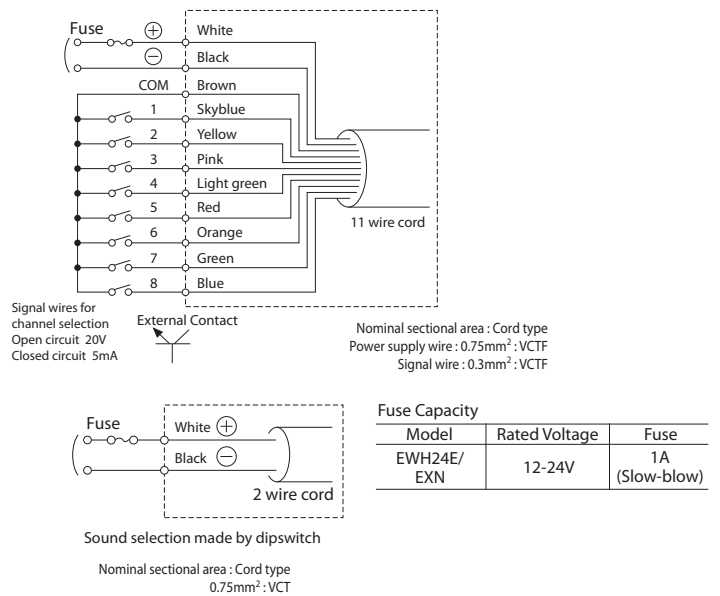

Test Switch

The test switch can be used to check the operation or adjust sound volume (Located under the cover).

Channel priority

8 (Blue) > 7 (Green) > 6 (Orange) > 5 (Red) > 4 (Lightgreen) > 3 (Pink) > 2 (Yellow) > 1 (Skyblue)
The greater number has priority when any of the channels are activated simultaneously.

■ Sound Selection Charts

- Pre-recorded on model EWH24E/EXN

Beep	Stutter + Bell	Inverted Revelle	Annie Laurie
Stutter	Synthesized Melody	Galactic Motor	London Bridge
Bell	Chime	Ringing Phone	Mary's Lamb
Yelp	Call Sign	Two Tone	Camptown Races
Rapid Hi Lo	Train Ride	Alarm Clock	Amaryllis
Melody Chime	Galloping Hi Lo	Ringing Hi Lo	Symphony #40
Synthesized Piano	Alien Chatter	Fur Elise	Ave Maria
Synthesized Bell	Falling Crystals	Minuet	Grandfather's Clock

■ Specifications

Model	Rated Voltage	Voltage Range	Power Consumption	Volume	Outer Contact Capacity	Operating Temperature Range	Auxiliary Input	Channel	Protection Rating	Mass
EWH24E/ EXN	12/24V AC/DC	8~28V AC 9~35V DC	8W	Max. 105dB at 1m	No more than 5A	-20°C~+60°C Humidity 85% or less.	EWH: Non-voltage Contact	8ch/1bit or 32ch/binary	IP65	1.2kg

CLT3024S/EXN EXPLOSION-SAFE

CE II 3 GD; Ex nA II T4; Ex tD A22 T135°C 94/9/EC CENELEC: EN60079-15, EN60079-0, EN61241-1, EN61241-0



- Explosion-safe for gas and dust
- Suitable for Zone 2 and Zone 22
- CE compliance in accordance to ATEX
- 350mm long
- 500 lx
- 24VDC, 416mA
- LED color: white 6750 K
- IP67F rated
- -30°C ~ +60°C
- Tempered glass lens
- Aluminum housing



CLT3024S/EXN



Specifications

Model	CLT3024S/EXN
LED Color	Day light Color
Rated Voltage	24V DC
Operating Voltage Range	Rated Voltage ± 10%
Current Consumption	416mA ± 40mA
Light Source	High intensity LED × 16 elements
Luminous Intensity at Optical Center (lx at 50cm)	500
Main Body	Housing: Aluminum, Cover: Tempered glass
Operating Temperature Range	-30 ~ +60 (No condensation 90%RH or less)
Mounting Direction	Any Direction (for indoor use only)
Protection Rating	IP66G/IP67G JIS C 0920: 2003/Aqueous oil resistant (Company Standards)
Vibration Resistance	19.6m/s ²
Mass	700g

Dimensions

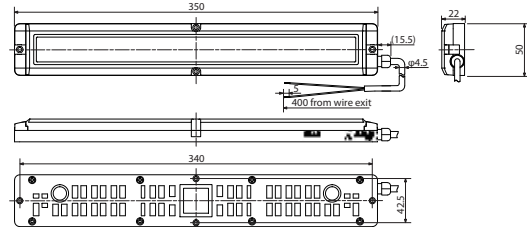

(Unit: mm)

CLF2024C/EXN EXPLOSION-SAFE

CE II 3 GD; Ex nA II T4; Ex tD A22 T135°C 94/9/EC CENELEC: EN60079-15, EN60079-0, EN61241-1, EN61241-0



- Explosion-safe for gas and dust
- Suitable for Zone 2 and Zone 22
- CE compliance in accordance to ATEX
- 220mm long
- 1,700 lx
- LED color: white 6800K
- IP67 rated
- -30°C ~ +60°C
- Polycarbonate lens
- Aluminum housing



CLF2024C/EXN



Specifications

Model	CLF2024C/EXN
LED Color	C
Rated Voltage	24V DC (No polarity)
Operating Voltage Range	Rated voltage ±10%
Power Consumption	5W
Light Source	High intensity LED×8
Luminous Intensity at Optical Center (lx at 50cm)	1,700
Main Body	Housing: Aluminum Cover: Polycarbonate
Operating Temperature Range	-30°C ~ +60°C (No condensation 90% RH or less)
Installation	Indoor, Forward Direction
Protection Rating	IP67
Vibration Resistance	19.6m/s ²
Mass	205g±10g

Dimensions

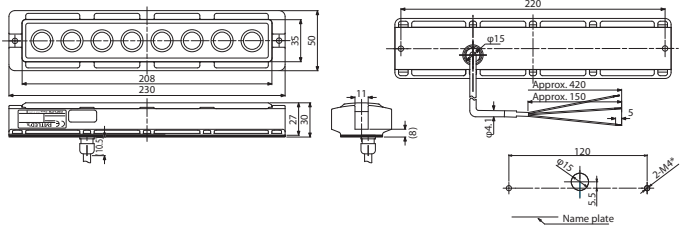

(Unit: mm)

CLA SERIES INTRINSICALLY-SAFE

CE II 3 GD; Ex nL IIC T4, Ex iD A22 T135 94/9/EC CENELEC: EN60079-15, EN61241-11, EN61241-0



- Explosion-safe for gas and dust
- Suitable for Zone 2 and Zone 22
- CE compliance in accordance to ATEX
- 100mm, 200mm and 300mm long
- 100mm: 140lx, 200mm: 270lx, 300mm: 400lx
- 24VDC (polarized)
- IP66, IP67 and IP69K rated
- -40°C ~ +60°C
- Polycarbonate
- Mounting brackets available



CLA3S24CD/EXN



Dimensions

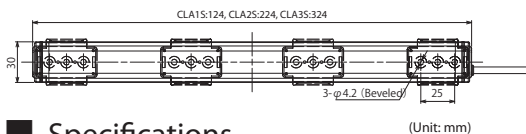

CLA S24 EXN

Length	LED color
1 100mm	CD Daylight 6800K
2 200mm	CN Natural white 4800K
3 300mm	

Options



*Stainless steel brackets are also available.

Specifications

Models	Luminous Color	Length	Rated Voltage	Operating Voltage Range	Rated Current Consumption	Center Radiation (lx/50cm)	Main Body Material	Operating Temperature Range	Mounting Direction	Protection Rating	Vibration Resistance	Mass
CLA1S24CD/EXN	Daylight	100mm	DC 24V (Polarized)	DC24V±10%	104mA	140	Body: Polycarbonate	-40 to +60 (RH 90% or less No Condensation)	Any Direction (Indoor Use)	IP66/67/69K	19.6m/s ²	80 g
CLA1S24CN/EXN	Natural White				208mA	270						
CLA2S24CD/EXN	Daylight	200mm	DC 24V (Polarized)	DC24V±10%	208mA	270	Body: Polycarbonate	-40 to +60 (RH 90% or less No Condensation)	Any Direction (Indoor Use)	IP66/67/69K	19.6m/s ²	130 g
CLA2S24CN/EXN	Natural White				240mA	400						
CLA3S24CD/EXN	Daylight	300mm	DC 24V (Polarized)	DC24V±10%	240mA	400	Body: Polycarbonate	-40 to +60 (RH 90% or less No Condensation)	Any Direction (Indoor Use)	IP66/67/69K	19.6m/s ²	180 g
CLA3S24CN/EXN	Natural White											

RES-A Heavy Duty Revolving Warning Light for Harsh Environment

Robust Heavy Duty Revolving Warning Light

- $\phi 224$ mm diameter.
- Integral Rotating Parabolic Reflector: For enhanced visibility from a distance.
- Installation: Indoors—upright, inverted, sideways; Outdoors—upright only.
- Main Body: Aluminum alloy die-cast with silver color baked finish.
- Dome: Acrylic resin covered with clear hard-glass, and metal guard.
- Available Colors: Red, Amber, Green and Blue.
- Approved by: TIIS (Technology Institution of Industrial Safety).
- IP66
- The metal cable gland is an optional part. Needs to order separately.



■ Dimensions

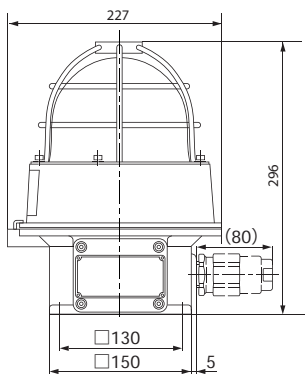

Mounting Dimension

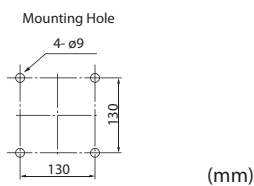

■ RES-A Type

Model	Rated Voltage	Current	Rotations per Minute	Bulb	No.	Mass
⊙RES-12A	12V DC	0.9A	170	12V10W	9	6.5kg
⊙RES-24A	24V DC	0.5A		24V10W	10	
⊙RES-48A	48V DC	0.3A	150	48V10W	11	
RES-100A	100~110V AC	0.1A	170	12V5W	12	
⊙RES-120A	115~120V AC					
RES-220A	200~220V AC	0.05A				
⊙RES-240A	230~240V AC					

Bulb--G18 BA155

⊙: Special Order

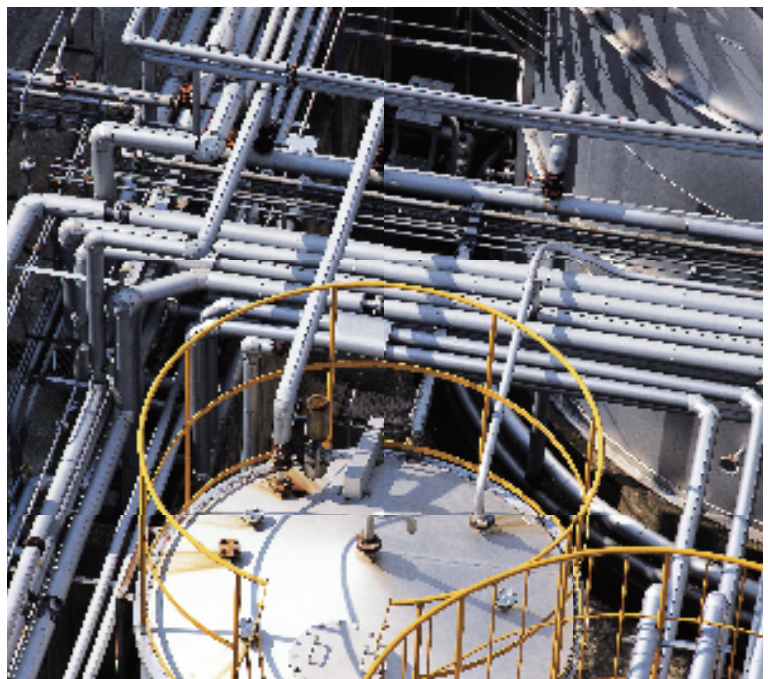

TIIS is a non-governmental, non-profit and self-sustaining organization founded in Japan in 1965 and recognized by the Minister of Health, Labor and Welfare as a juridical incorporation, to help reduce industrial accidents and contribute towards the benefits of industrial sectors in Japan through its various technological activities.

RLR Robust Heavy Duty 11.2G LED Super Bright Beacons for Harsh Environment



- 162mm diameter
- 11.2G Anti-Vibration
- IP66 Protection
- Robust Heavy-duty Design
- Dual LED with Twin Reflector
- Maintenance-free with Brushless Motor
- Strong Polycarbonate Housing
- CE Compliant (12/24VDC)



LED + Brushless Motor + Bearing Mechanism



Long Life

The RLR has many advantages compared to a rotating beacon with incandescent bulb and standard motor. The LEDs last approximately 20 times to 40 times longer than an incandescent bulb. The combination of the brushless motor and bearing mechanism allows the RLR to operate from 8,000 hrs to 10,000 hrs, compared to 5,000 hrs for other rotating beacons.

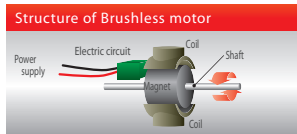
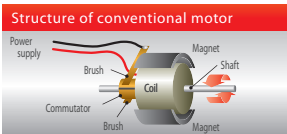

Vibration Resistance ※
※Except RLR-M2

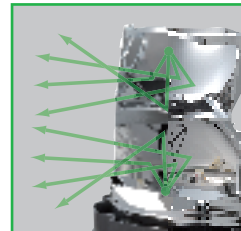

High Visibility



High Protection

Dimensions

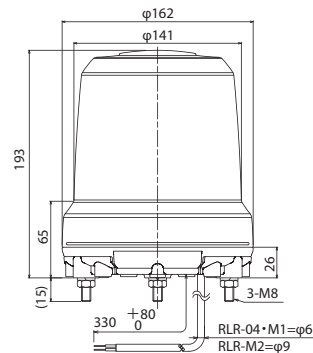

Model Code

RLR-04-P-R	
Rated Voltage	Color
04 : 48V DC	R : Red G : Green
M1 : 12/24V DC	Y : Amber B : Blue
M2 : 90V AC~250V AC	Mounting Dimensions
	Blank : φ140
	P : φ120

Specification

Model	Rated Voltage	Operating Voltage Range	Vibration Resistance	Operating Temperature Range	Dome	Mass
RLR-M1	12/24V DC	9.5~15V DC	110m/s ² (11G)	-30°C~+70°C	-R (Red) -Y (Amber) -G (Green)	1.0kg
RLR-M2	90~250V AC	90~250V AC	45m/s ² (4.5G)	-10°C~+50°C	-B (Blue)	1.06kg

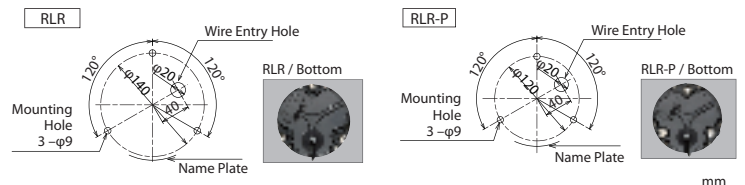

Passenger Car



Construction Machinery



Emergency Vehicle



Dump Truck

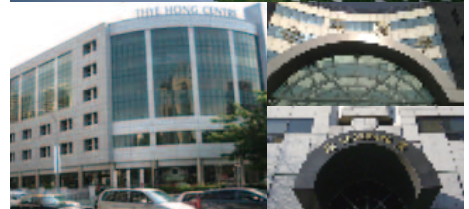

<http://www.patlite.com> e-mail:overseas@patlite.co.jp

PATLITE Corporation

8-8, Matsuyamachi, Chuo-ku, Osaka, Japan 542-0067
International Division, Sales and Marketing Department
TEL: +81-6-6763-8220 FAX: +81-6-6763-8221

PATLITE (U.S.A.) Corporation E-mail:sales@patlite.com

20130 S. Western Ave. Torrance, CA90501, U.S.A.
TEL: +1-310-328-3222 FAX: +1-310-328-2676

PATLITE (SINGAPORE) PTE LTD E-mail:sales@patlite.com.sg

No.2 Leng Kee Road, #05-01 Thye Hong Centre, Singapore 159086
TEL: +65-6226-1111 FAX: +65-6324-1411

PATLITE (CHINA) Corporation E-mail:sales@patlite.cn

Room 512, Jufeng Business Building, No.697-3 Lingshi Road, Shanghai China 200072
TEL: +86-21-6630-8969 FAX: +86-21-6630-8938

PATLITE Europe GmbH E-mail:info@patlite.eu

Am Soeldnermoos 8, D-85399 Hallbergmoos, Germany
TEL.+49-811 9981 9770-0 FAX.+49-811 9981 9770-9

PATLITE KOREA CO., LTD. E-mail : sales@patlite.co.kr

202 Seokwang Bldg. 1361-9 Seocho-dong, Seocho-gu, Seoul, 137-863
TEL.+82-2-523-6636 FAX.+82-2-523-6637

P.T. PATLITE INDONESIA (FACTORY)

LOT 321 Batamindo Industrial Park, Jalan Beringin Mukakuning, Batam 29433 Indonesia
TEL: +62-770-61-1123 FAX: +62-770-61-2444



To ensure correct use of these products, read the Instruction Manual prior to use.
Failure to follow all safeguards can result in fire, electric shock, or other accidents.
Specifications are subject to change without notice.

ISO14001
ISO 9001
Certified

Headquarters
Sanda Plant
Techno Center



PATLITE ECO PROJECT

For the benefit of mankind and the earth, PATLITE is committed to developing environmentally friendly products.

Sanda Plant	
Headquarters	PATLITE (U.S.A.)
PATLITE Europe GmbH	
PATLITE (SINGAPORE)	PATLITE (CHINA)
	PATLITE KOREA

